

# CITIZEN

# Cincom

## M16

Sliding Headstock Type CNC Automatic Lathe



## The M16: A high-end model covering Ø16 mm

The M16: A high end model available with both a B axis capable of working on both spindles, and also a Y axis on the back tool post.

The M16 type VIII features a B axis for rotary tools on the gang tool post. It can machine angled holes and complex shapes. The swivel angle of the B axis is 135° and it can be used in both front and back machining. The back tool post is equipped with a Y axis (types VIII) and up to 9 tools can be carried in 3 rows.

Equipped with rapid feed rates up to 32m/min and increased spindle speeds it can machine with optimum conditions for small diameter workpieces and tools.

With a compact footprint it is ideally suited to production of increasingly complex parts in the medical and IT sectors.



## Tooling system

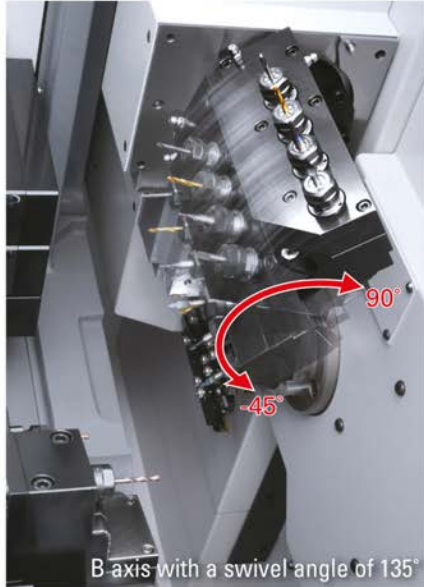

### Rotary tools on the gang tool post equipped with B axis \*Type VIII

On the M16 type VIII, the rotary tools on the gang tool post feature a B axis as standard, and four tools each can be mounted for back and front machining. The swivel angle has a range of 135°, from 90° to -45°, and the machine is capable of contouring using 4-axis control, with the B axis used even in back machining.



### Y axis incorporated in the turret tool post

Because the 10-station turret tool post incorporates a Y axis, a wide variety of secondary machining is possible. The tool post can be indexed without going back to the return position, shortening tool change times. Each tool station is driven and can carry multi-tool holder.

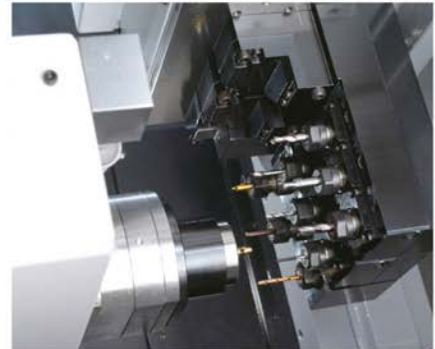
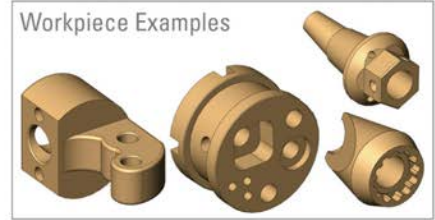

### Y axis incorporated in the back tool post \*Type VIII

The back tool post can accommodate nine tools in 3 rows of 3 tools. The specifications of the outer diameter milling spindle (MSC507), 3-drilling spindle (MSE607) and 3-sleeve holder (MDF107) are common to those used on the gang tool post and they can be used both on the gang tool post and the back tool post.

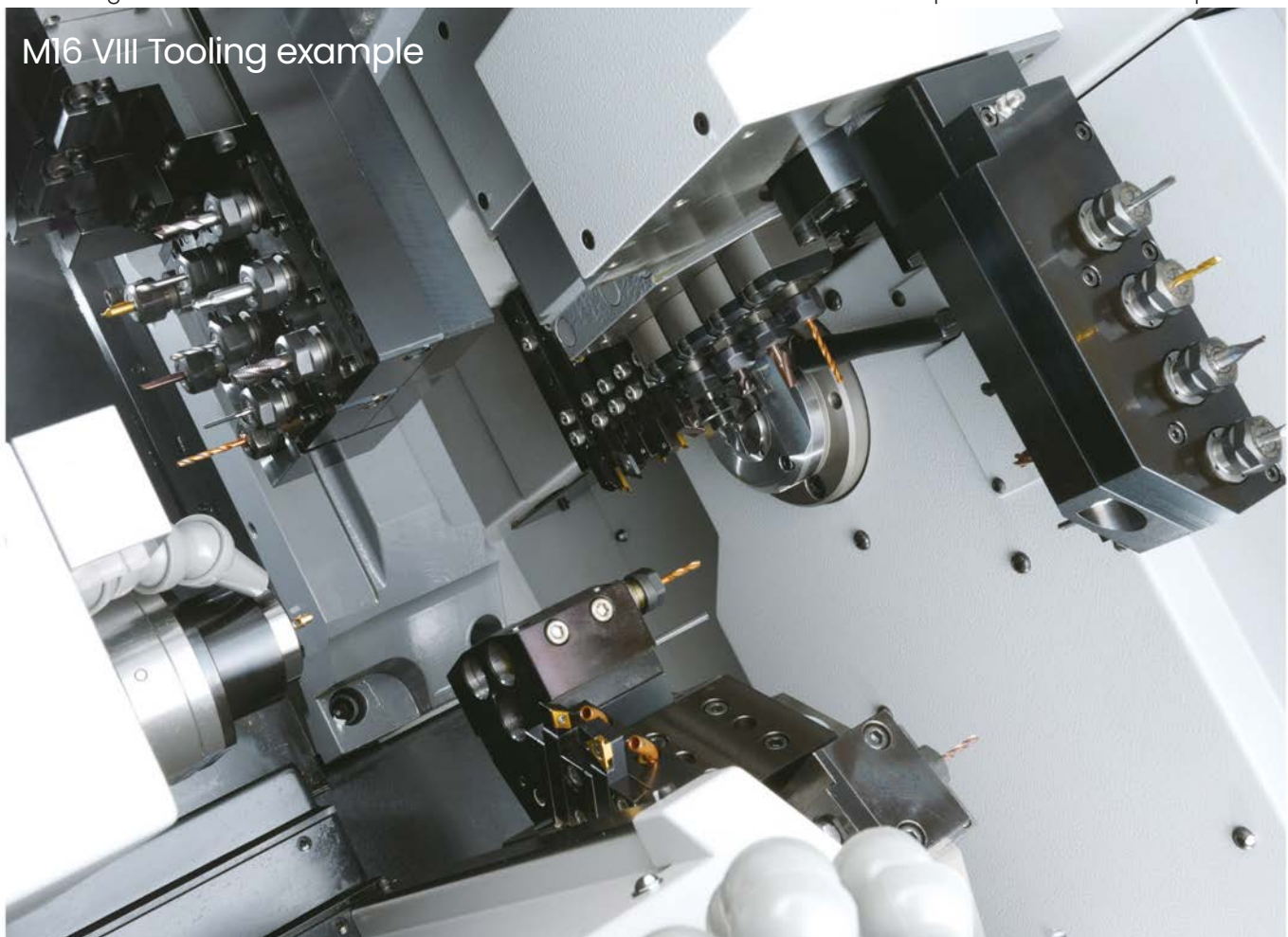

M16 VIII Tooling example

# Faster. Achieving a higher level of stable operation

High speed and excellent maintainability linked to productivity improvements

## Rapid feed rate of 32 m/min, and 20% reduction in idle time

The rapid feed rate of the major feed axes has been substantially increased to 32 m/min. The adoption of the latest NC unit with a high-speed CPU on board, in combination with Citizen's original control technology "Cincom Control", cuts idle time by 30%.

## High-speed spindle and tool spindle

High-speed rotation has been achieved for the front/back spindles with their maximum speed of 12,000 min<sup>-1</sup>, and for the gang tool spindle, turret tool spindle and back tool post tool spindle \* types VII and VIII with their maximum speed of 8,000 min<sup>-1</sup>. This means that the optimum machining conditions can be used when machining small-diameter bar material and when using small diameter drills/end mills.

## Air Seals

Air seals are used as a standard feature in the front spindle, guide bushing and rear spindle, and this restricts the entry of coolant and chips and guarantees stable operation for extended periods.

## Central lubrication device

A central lubrication device is installed as standard. The automatic supply of lubricating oil to all ball screws eliminates the need for manual greasing and improves maintainability.

## Oil supply to rotary tools on the gang tool post

The gang tool post rotary tool drive device is equipped with an automatic lubrication function as standard, limiting wear of the gears over the long term and assuring high reliability.

## Cincom Control

"Cincom Control" is Citizen's unique control system specially developed to enable smooth motion at high speeds. It slashes idle time without adversely affecting cutting, achieving a remarkable reduction of cycle time.

## Idling Stop

When the spindles and feed axes are stopped, for example during editing, the servo turns OFF and the amount of power in the standby status is reduced. Note that the cumulative reduction in the amount of power since installation can be checked on the Eco screen.



# Operability fully considered too, with 2 types selectable to match the application

Type V for excellent cost performance and Type VIII featuring a gang tool B axis

## M16 Type VIII

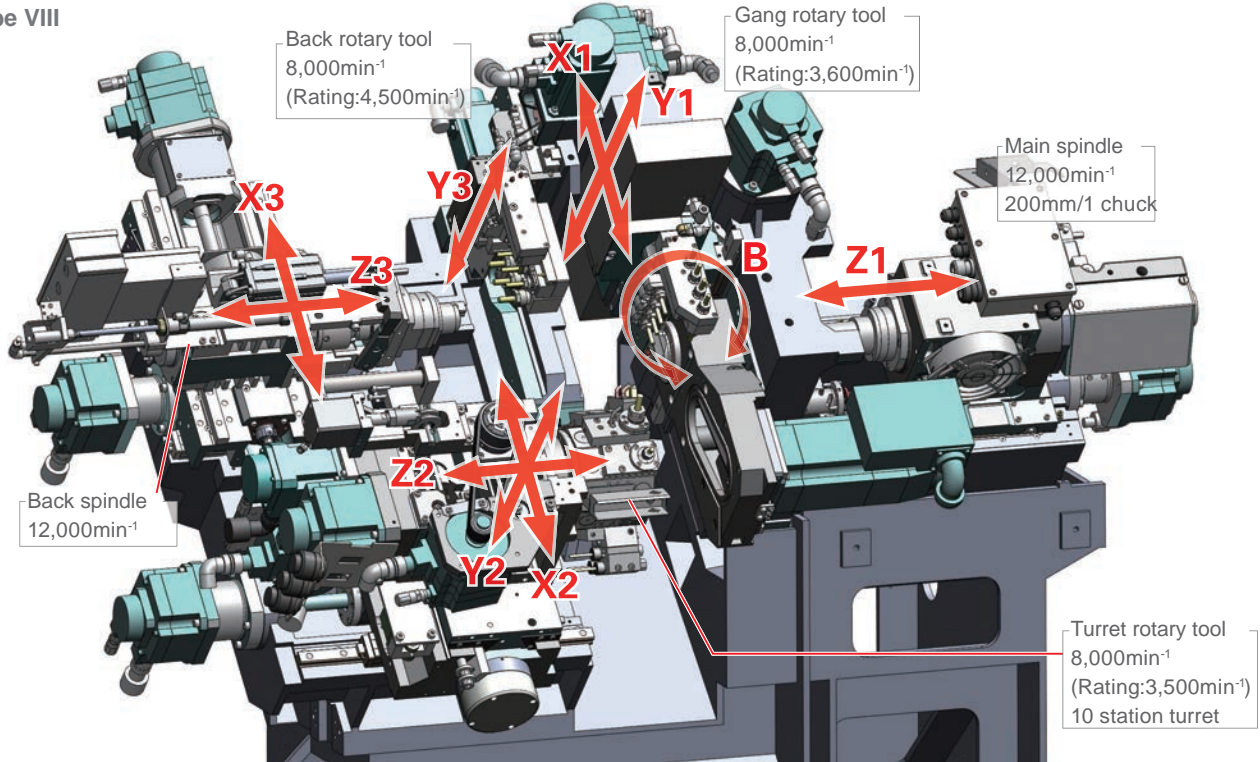

Back tool post of the Type V M16

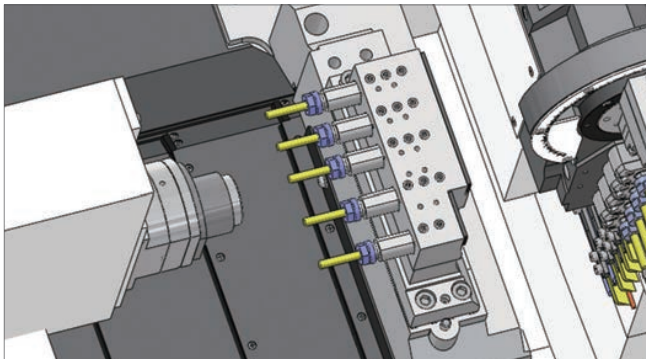

M16 configuration according to type

	Type V	Type VIII
Y2 axis (turret Y axis)	<input type="radio"/>	<input type="radio"/>
Y3 axis (back tool post Y axis)	-	<input type="radio"/>
B axis (rotary tools on the gang tool post)	-	<input type="radio"/>



### Swing-out operation panel

The operation panel with high visibility colour screen that pivots about two points, enabling it to be conveniently positioned for tasks such as editing and tool setting.



### Product collection

Machined products are consigned to this receiver box through the turret-mounted basket. Products up to 125 mm in length can be collected. Optional accessories include workpiece conveyor and workpiece unloader.



### Oil cooler fitted as standard for rotary tools

For rotary tools on the gang tool post and rotary tools on the back tool post, an oil cooler is installed as standard.

# Intuitive screen display is easy to view and read



## Equipped with high-speed NC

The machine is equipped with the latest NC model to drastically reduce the startup and screen switching time compared to conventional machines with advanced functions. This feature provides a stress-free operation environment.



## On-machine program check function

Using the manual pulse handle, an NC program can be run forward and backward so that the program can be edited by stopping the operation at a desired point and then resuming according to the edited program.

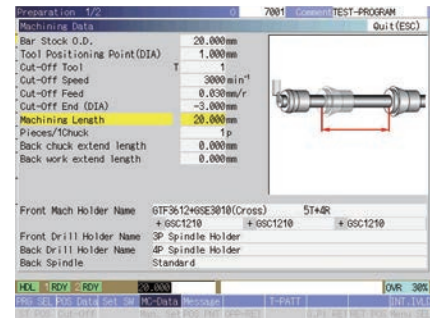

## Display of easily understood illustrations

The corresponding illustration is displayed on the screen so that the operator can easily recognize the meaning of the associated data.

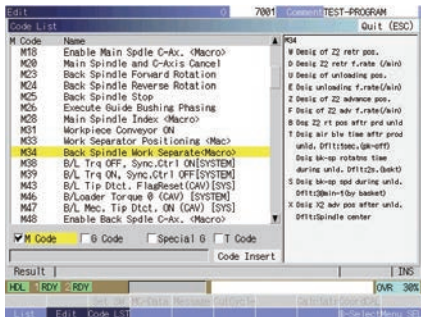

## Display of code list

The function displays the list of G and M codes including explanations of the arguments to support programming.

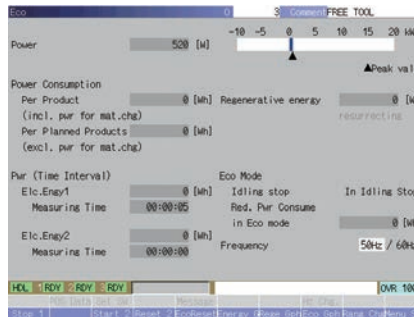

## Eco screen

The current power consumption is shown on the screen, along with the maximum power consumption value, the power consumption record, the cumulative power consumption, and the power regeneration (generation) status. Data can be output, too.

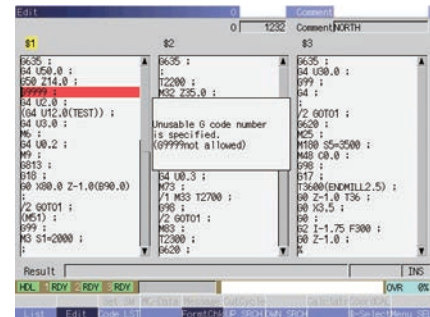

## Grammar check function

The customer can check whether there are any syntax errors in the program before running it. And if an alarm occurs, the relevant block is highlighted.

## Product Unloader

By installing a product unloader, the collection time with the turret can be reduced, helping to shorten cycle times. The unloader can collect products with lengths from 125 to 400 mm, and can also be used in combination with the long workpiece unit that draws the products out from the rear of the back spindle with a work hand.

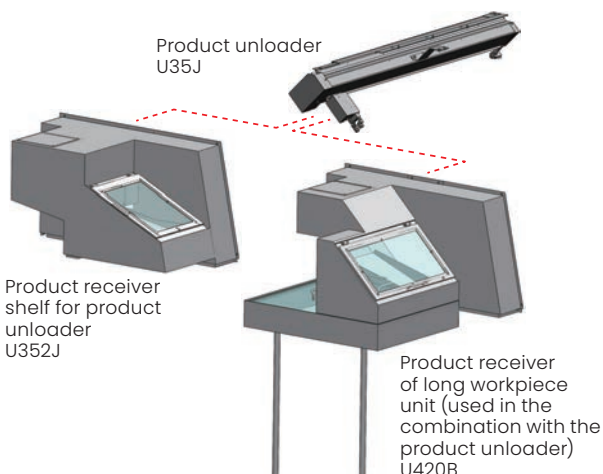

## LFV



LFV\* (low-frequency vibration) cutting is a technology for cutting in which each X/Z servo axis is vibrated in the cutting direction and synchronized with the spindle speed. This reduces various types of problems such as cutting chips being caught up in components, workpieces or cutting tools, and enables small diameter deep hole drilling and machining of materials that are difficult to cut.

Model	Front side LFV	Back side LFV	LFV mode 1	LFV mode 2	LFV mode 3
V	X1, Z1	X2, Z2	✓	✓	✓
VIII	X1, Z1	X2, Z2	✓	✓	✓

1. LFV machining cannot be performed with the Y axis.
2. Up to one pair (= two axes) can be operated simultaneously as LFV machining.
3. LFV machining using rotary tools requires the "LFV function" and "Rotary tool per rotation feed rate" options.

\* LFV is a registered trademark of Citizen Watch Co., Japan.

# Machine layout

M16 Standard  
Machine Layout

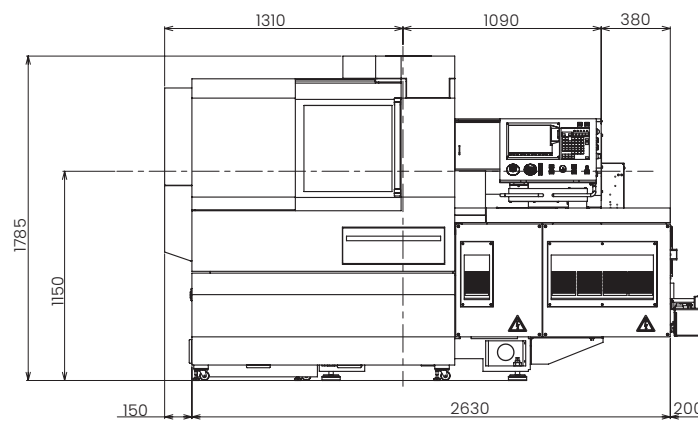
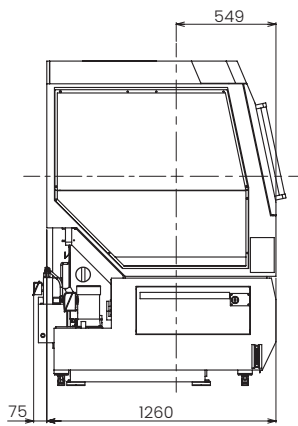
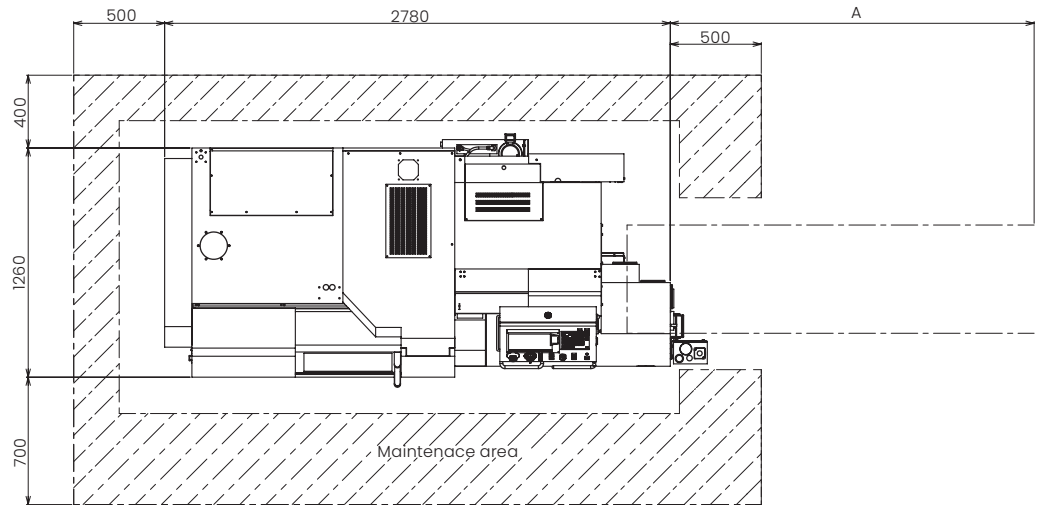

Reference for dimensions

	2.5m	3.0m	4.0m
Ikura OS20RE	3164mm	3664mm	4664mm
Alps ASRX-16Z	2968mm	3468mm	4468mm

M16 Standard  
Machine Layout

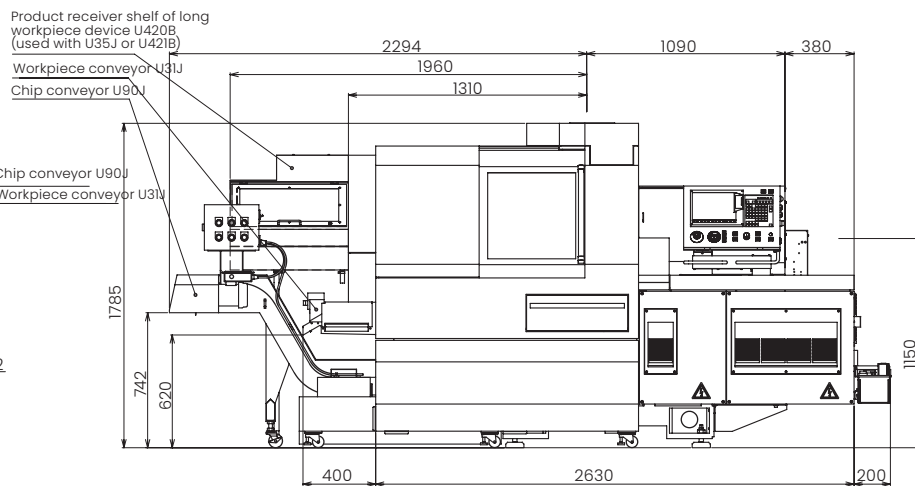
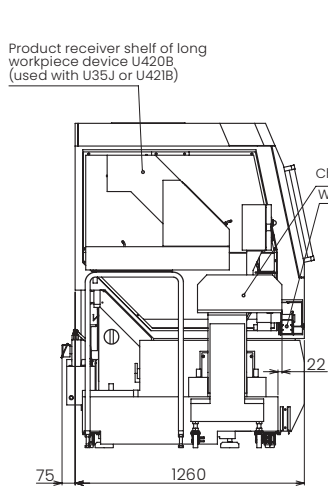
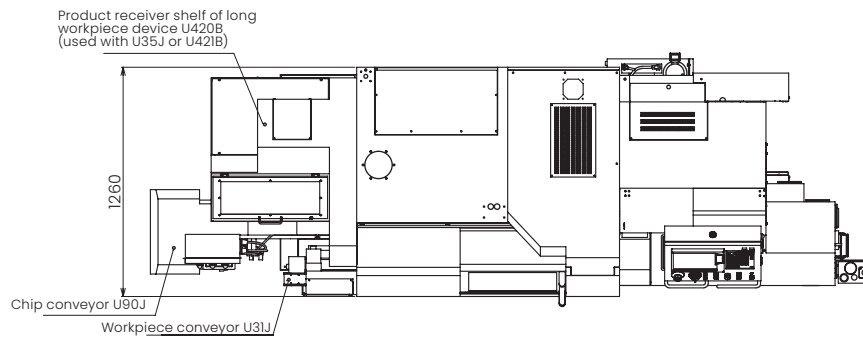

Status with M416, U420B, U31J, U90J fitted

# Machine specification

Item	M16-4M5	M16-4M8	Standard accessories
Max. machining diameter (D)	6mm		Main spindle chucking unit      Workpiece separator
Max. machining length (L)	200mm/l chucking		Rotary guide bushing unit      Machine relocation detector
Spindle through-hole diameter	20mm Dia.		Back spindle chucking unit      Lighting
Main spindle speed	Max12,000min <sup>-1</sup>		Gang rotary tool driving unit      Door lock
Max. chuck diameter of back spindle	16mm Dia.		Coolant unit (with level detector)
Max. protrusion length	125mm		Lubricating oil supply unit (with level detector)
Max. protrusion length of back spindle workpiece	30mm		Air-driven knock-out device for back machining
Back spindle speed	Max12,000min <sup>-1</sup>		
Gang rotary tool			<b>Special accessories</b>
Spindle speed	Max12,000min <sup>-1</sup> (Rating 3,600min <sup>-1</sup> )		Cut-off tool breakage detector      Workpiece conveyor
Turret rotary tool			Long workpiece unit      Chip conveyor
Spindle speed	Max12,000min <sup>-1</sup> (Rating 3,500min <sup>-1</sup> )		Product unloader      Signal lamp
Back tool post rotary tool			Coolant flow rate detector      3-colour signal tower
Spindle speed	-	Max. 8,000 min <sup>-1</sup> (Rating 4,500min <sup>-1</sup> )	Medium-pressure coolant unit      LFW
Number of tools to be mounted	32+a	36+a	Knock-out jig for through-hole workpiece
Gang turning tool	5		Motor-driven knock-out device for back machining
Gang rotary tool	5-12 (including back 4 tools)		
Turret	10+a		<b>Standard NC functions</b>
Back tool post	5	9	NC unit dedicated to the L12 (M730LPC-4VS)
Tool size			10.4 inch colour liquid crystal display (LCD)
Tool (turning tool)	10mm		Program storage capacity : 40 m (approx16KB)
Sleeve	19.05mm Dia.		Product counter indication (up to 8 digits)
Main spindle collet chuck	F20		Constant surface speed control function
Guide bushing	F20		On-machine program check function
Back spindle collet chuck	B238		Tool offset pairs : 40      Automatic power-off function
Rapid feed rate			Operating time display function      Nose radius compensation
All axes (except X2, Y2, Y3 & B axes)	32m/min		Spindle speed change detector      Chamfering, corner R
X2 axis	16m/min		Spindle C-axis function      Format check function
Y2 axis	8m/min		Alarm block display function      Eco display
Y3 axis	-	32m/min	Machine operation information display
Motors			
Spindle drive	2.2/3.7kW		<b>Special NC functions</b>
Gang tool post rotary tool drive	0.69kW		Variable lead thread cutting      Tool offset pairs: 80
Turret rotary tool drive	0.69kW		Arc threading function      Tool life management I
Back spindle drive	0.75/1.5kW		Geometric function      Tool life management II
Back tool post rotary tool drive	-	0.75kW	Spindle synchronised function      Milling interpolation
Coolant oil	0.4kW		Back spindle I <sup>o</sup> indexing function      Network I/O function
Centre height	1,150mm		Back spindle C-axis function      Submicron commands
Rated power consumption	7.9kVA		Back spindle chasing function      User macros
Full-load current	28A		Canned cycle drilling      Helical interpolation function
Main breaker capacity	40A		Rigid tapping function      Hob function
Air pressure and air flow rate for pneumatic devices	0.5MPa, 84NL/min (normal) / 220NL/min (blow)		High speed Rigid tapping function      Polygon function
Weight	2,900kg	2,950kg	Optional block skip (9 sets)      Inch command
			Differential speed rotary tool function      Sub inch command
			3D camfering function
			Rigid tapping phase adjustment function
			Back machining program skip function
			Program storage capacity : 1200 m (approx480KB)
			External memory program driving
			Inclined helical interpolation function

## Citizen Machinery UK Ltd

1 Park Avenue, Bushey WD23 2DA, UK  
Hurst Business Park, Narrowboat Way, Brierley Hill DY5 1UF, UK  
Tel. +44 (0) 1923 691500 | sales@citizenmachinery.co.uk

www.citizenmachinery.co.uk

ASIA  
Headquarter Japan | Citizen Machinery Co., Ltd., 4107-6 Miyota, Miyota-machi, Kitasaku-gun, Nagano-ken, 389-0206, Japan, Tel. +81-267 325 901  
EUROPE  
Headquarter Europe | Germany | Mettinger Straße 11, 73728 Esslingen, Tel. +49-711 3906 100 | France | Citizen Machinery France S.A.S., ZAE des Lacs 3, 1385 Avenue du Mole, 74130 AYSE, France, Tel. + 33-450 985 269 | Italy | Citizen Machine Italia s.r.l., Via Campo Romano 11/13 - 24050 Spirano (BG), Italy, Tel. +39-035 877 738 | Spain | Egasca, S.A., Poligono Industrial Erisono 2, 20600 Elbar, Gipuzkoa, Spain, Tel. +34-943 200 300 | UK | Citizen Machinery UK Ltd, 1 Park Avenue, Bushey, WD23 2DA, UK, Tel. +44-1923 691 500

Images may differ from the original. Technical data is subject to change without notice. The product falls under the export regulations and is subject to the foreign exchange and external trade law. Before exporting this product please refer to your CITIZEN dealer. Please also contact your CITIZEN dealer before you intend to resell, export or take this product somewhere else. Any copy of this product no matter whether in whole or in parts as well as its relating technologies and software is forbidden. In case of export the export licence issued by the competent authorities has to be presented to CITIZEN. The machine operation may be started upon confirmation and approval by CITIZEN. CITIZEN is a registered trademark of Citizen Watch Co. Japan. Subject to technical changes and error. Specifications only apply to the European market. Published 03/2026.